

TANK DIA.
UP TO **30 ft.** (9.1 m)

TANKJET® YMD3 TANK CLEANER

TANKJET YMD3 TANK CLEANER FEATURES AND BENEFITS

- Dependable and durable motor-driven units provide consistent, high-impact cleaning to remove the most stubborn residues
- Air/electric motors rotate solid stream nozzles in three directions to efficiently cover the entire tank
- Extension lengths available from 3.3 ft. (1 m) to 8.2 ft. (2.5 m)
- Reduces the need for dangerous and time-consuming manual tank cleaning
- Wide range of nozzles available to fit specific applications

SPECIFICATIONS

TankJet YMD3 Tank Cleaner	
Max. tank diameter:	30 ft. (9.1 m)
Operating principle:	Motor-driven
Flow rate:	8.6 to 37.5 gpm (32.6 to 142 lpm)
Operating pressure:	725 to 4350 psi (50 to 300 bar)
Max. temperature:	176°F (80°C)
Materials:	316 stainless steel, PTFE and fluororubber
Inlet connection:	1/2" NPT and BSPT (F)
Flange:	ASME®, JIS, and sanitary options available
Motor options:	Air, electric
Optional accessories:	Strainers, recommended mesh size: 100 (150 micron) See page G2

IDEAL FOR CLEANING:

- Chemical reactors
- Food processing tanks and vats
- Pharmaceutical processing vessels
- Process tanks



TankJet YMD3
tank cleaner
with air motor

TankJet YMD3
tank cleaner

HI
HIGH
IMPACT

**SPRAY
COVERAGE**

360°



**MOUNTING
OPTIONS**

Vertical	↑	↓
Horizontal	←	→
45° Up	↖	↗
45° Down	↙	↘

DIMENSIONS AND WEIGHTS

Model	Min. Tank Opening in. (mm)	L in (mm)	A Extension Length ft. (m)	B Overall Length in. (m)
YMD3-A (Air Motor)	3.8 (95)	6.7 (170)	3.3 to 8.2 (1 to 2.5) in 0.8 (0.25) increments	A + 16.8 (426)
YMD3-E (Electric Motor)	3.8 (95)	6.7 (170)		A + 14 (356)

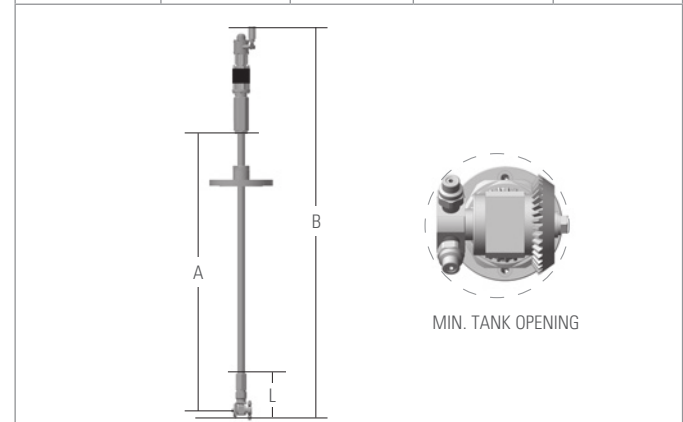

PERFORMANCE DATA

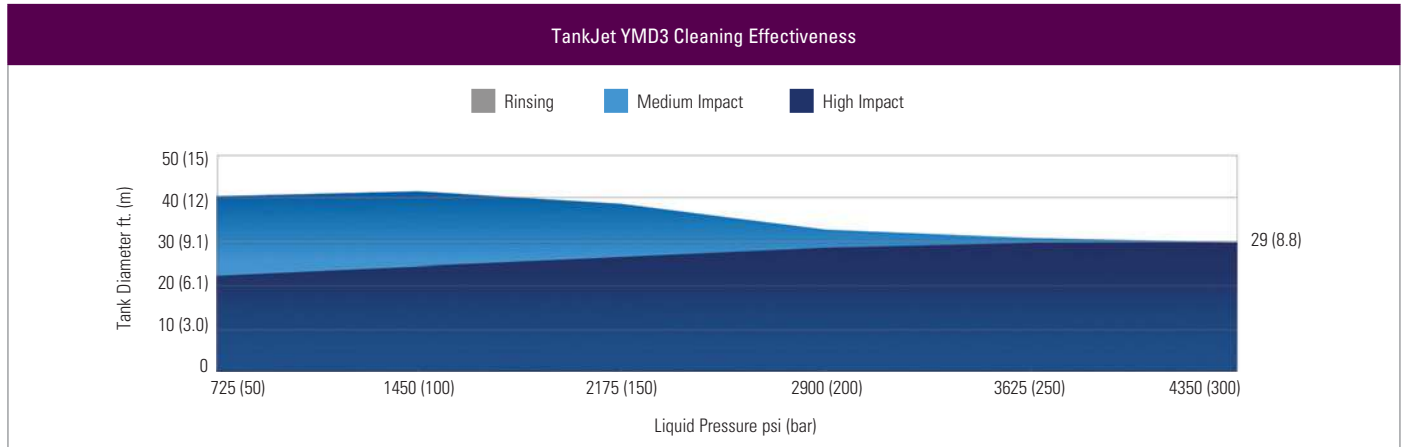

Model YMD3		Total Flow of Equal Capacity, gpm (lpm)* Liquid Inlet Pressure			
Nozzle	Capacity Size	725 psi (50 bar)	1450 psi (100 bar)	2900 psi (200 bar)	4350 psi (300 bar)
1/8MEG	0005	8.6 (32.6)	12 (45.5)	16.2 (61.2)	20.3 (77)
	0010	15.9 (60)	21.9 (82.8)	30.5 (115.5)	37.5 (142)

*Note: Flow rates tabulated above include pressure drop through unit.

**AIR MOTOR
CYCLE TIME DATA**

Air Pressure	Air Consumption	Approx. Speed (rpm)		Approx. Time for One Complete Cycle (min.)	
		Liquid Pressure psi (bar)		Liquid Pressure psi (bar)	
psi (bar)	scfm (l/sec)	725 (50)	4350 (300)	725 (50)	4350 (300)
6 (0.41)	2.3 (65)	3.6	4.7	10.3	7.9
8 (0.55)	3.2 (91)	9.0	9.0	4.1	4.1
10 (0.68)	4 (113)	11.5	11.6	3.2	3.2

**ELECTRIC MOTOR*
CYCLE TIME DATA**

Frequency @ 115 VAC	Speed (rpm)	Current (amps)	Power (watts)	Approx. Time for One Complete Cycle (minutes)
50 Hz	17	23	25	2.5
60 Hz	20	21	25	2

For lances, mounting kits, adapters and more, see page G6

ORDERING INFORMATION

Call your local spray expert for application assistance or to place an order.

